

Irrigation and Drainage Engineering

(Soil Water Regime Management)

(ENV-549, A.Y. 2025-26)

4ETCS, Master option

Prof. Paolo Perona

Platform of Hydraulic Constructions



Lecture 5.1. Gravity irrigation:
water control and
redistribution

Automatic gate with constant upstream level (AML gates)

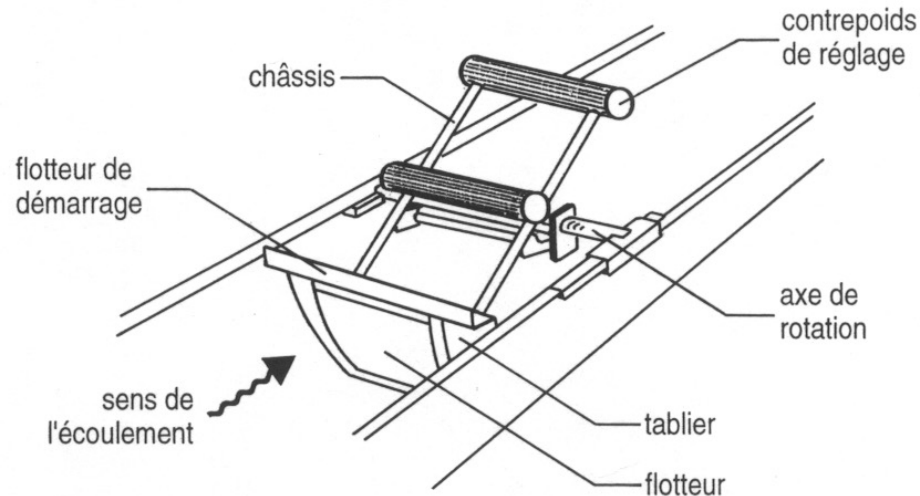

WORKING PRINCIPLE

The only torques involved are that due to the weight P and that due to the buoyancy F on the float.

The valve is balanced so that these two torques are equal and opposite for any position of the gate, when the upstream level is at the setting level.

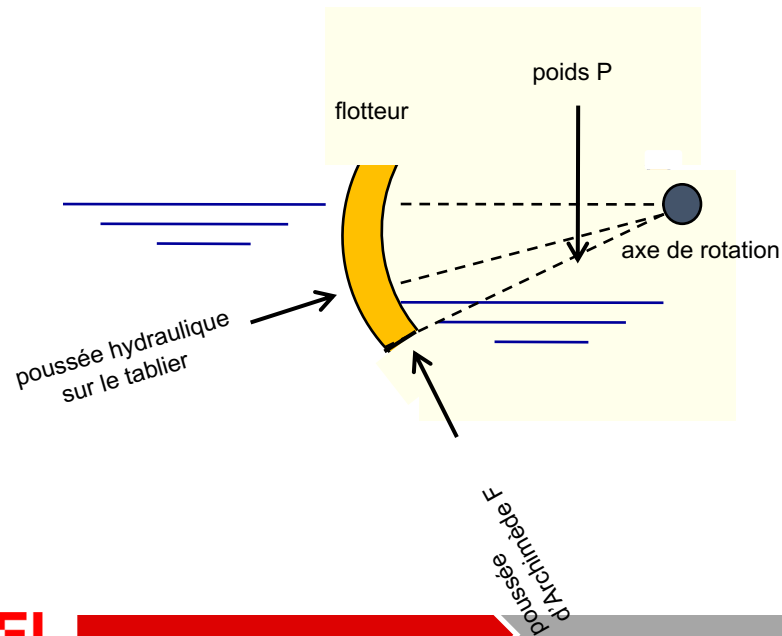

Cross-section and plan view of a section of canal with upstream regulation

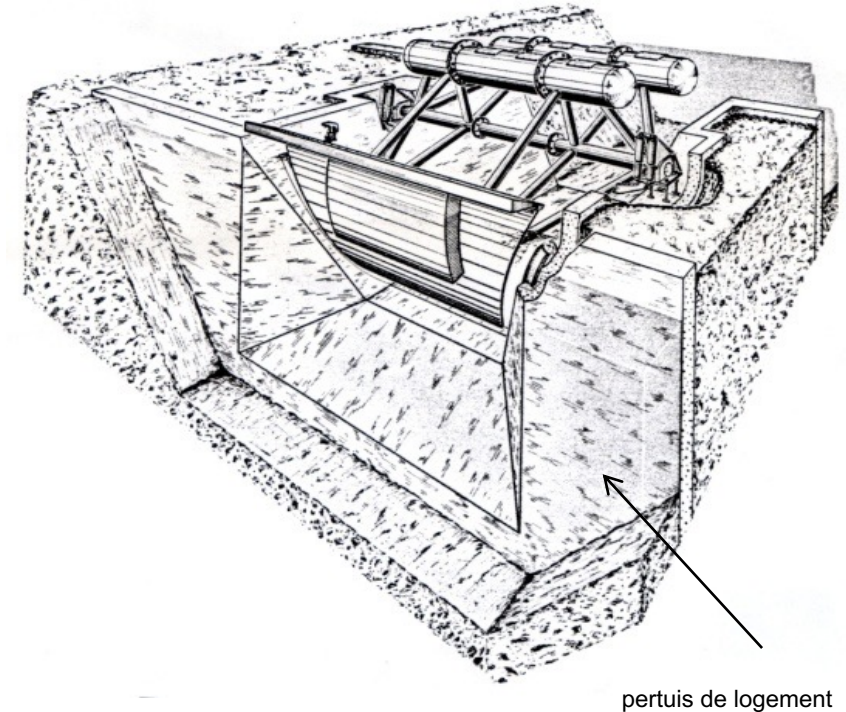
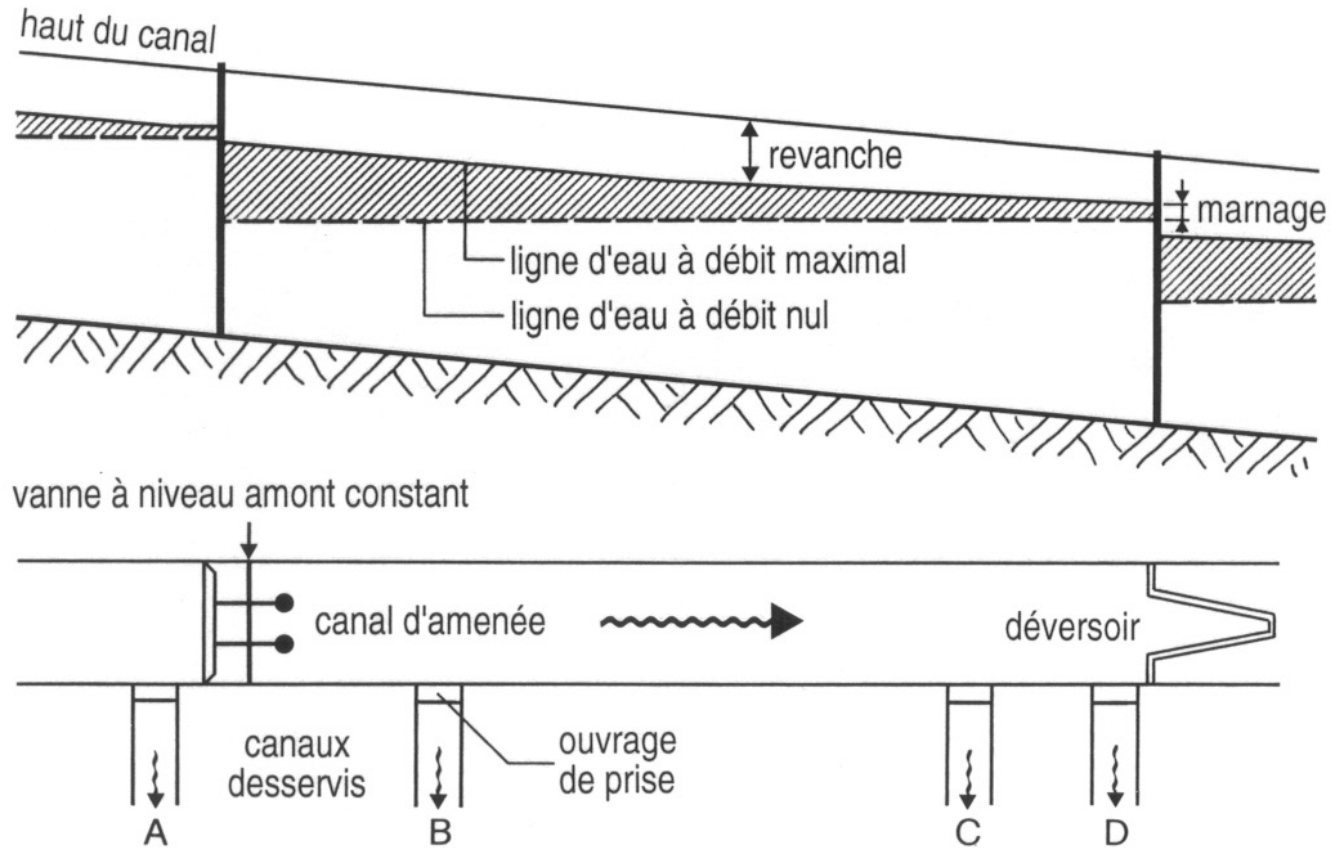

The position and density of the control structures depends on:

- channel slope
- position of bypass channels
- admissible tidal range
- imposed constraints



EPFL campus (irrigation loop)

Real scale application



Dynamical behavior and instability



Fig. 1. (Color) Experimental AMIL gate exhibiting oscillating behavior and creating waves

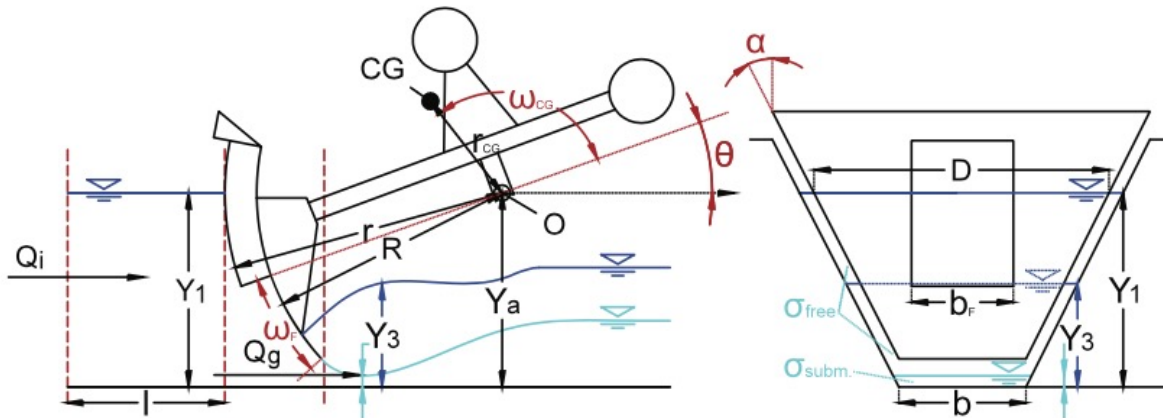

Fig. 2. (Color) Longitudinal and cross-section illustration of gate giving the geometric parameters

Dynamical Behavior and Stability Analysis of Hydromechanical Gates

Fabian A. Bernhard¹ and Paolo Perona²

Abstract: This study revisits the stability of hydromechanical gates for upstream water surface regulation, also known as AMIL gates. AMIL gates are used in irrigation canals, where they are often installed in series. From the regulation perspective, instabilities are undesired because they generate waves and fluctuations in the discharge. A mathematical model for an AMIL gate is described as a nonlinear dynamical system, which permits analyzing the dynamic interaction between the local water level and the gate position. The feedback effect of the gate on the water level is introduced by considering a storage volume of length l . In the derived model, waves are simplified to fluctuations of the flat water surface of the storage volume. Although previous studies used the same model, none has clarified the sensitivity of the model to the parameter l . The role of this parameter is investigated and it is calibrated with experimental measurements. The precision of the regulation is described by the decrement, the range of the water level around the target level. Based on the mathematical model, a relationship for calibration of the gate and precision of regulation is presented. The subsequent stability analysis of the dynamical system focuses on five control parameters and sheds light on their influence on the gate behavior. Hopf bifurcations are identified, which separate stable equilibrium solutions from stable periodic solutions. Further work might consider the implications of the periodic solutions on gates that work in series, as well as envision the innovative use of such gates outside of the domain of irrigation canals to obtain dynamic environmental flows in hydropower systems. DOI: 10.1061/(ASCE)IR.1943-4774.0001209. © 2017 American Society of Civil Engineers.

Introduction

Hydromechanical gates for upstream water surface regulation, also known as AMIL gates, are used in gravity irrigation systems to control water levels upstream of their location for varying flow rates in the main canal (Rogers and Goussard 1998; Ramirez-Luna 1997; Montañés 2005; GEC Alstom 1992). This flow rate may vary if the inflow upstream changes or as water is removed via lateral off-takes from the main canal according to a varying demand.

AMIL gates are a specific type of radial gates, used as automatic control structures in order to cope with these variations in flow rate by opening or closing in response to the current water level. Their objective is to maintain the water level in a certain range around their trunnion axis. This range is referred to as *decrement* (Ramirez-Luna 1997; GEC Alstom 1992) and can be related to the gate properties (calibration of mass and center of gravity).

A photo and an illustration of an AMIL gate are shown in Figs. 1 and 2. In addition to typical radial gates, they are equipped with a toroidal float attached to the upstream side of the gate leaf, counterweights on the downstream side, and a damping device to reduce oscillations. Because the gate is operated only by the water force, AMIL gates are counted among the hydromechanical gates (Cassan et al. 2011).

¹Research Associate, CRYOS, Laboratory of Cryospheric Sciences, Institute of Environmental Engineering, School of Architecture, Civil and Environmental Engineering, École Polytechnique Fédérale de Lausanne, Station 2, CH-1015 Lausanne, Switzerland (corresponding author). E-mail: fabian.bernhard@alumni.epfl.ch

²Professor and Chair of Environmental Engineering, Institute for Infrastructure and Environment, School of Engineering, Univ. of Edinburgh, Edinburgh EH8 9YL, U.K. E-mail: paolo.perona@ed.ac.uk

Note. This manuscript was submitted on December 21, 2016; approved on March 7, 2017; published online on July 7, 2017. Discussion period open until December 7, 2017; separate discussions must be submitted for individual papers. This paper is part of the *Journal of Irrigation and Drainage Engineering*, © ASCE, ISSN 0733-9437.

Through the interaction of the gate and the local water level, oscillations are possible and are indeed observed, particularly when the damping element is worn out (Ramirez-Luna 1997; Montañés 2005; Bernhard 2015). Fig. 1 and Videos S1 and S2 show an aged experimental AMIL gate at École Polytechnique Fédérale de Lausanne in Switzerland (EPFL) that exhibits an oscillating behavior. This behavior was triggered by operation of the lateral off-take structures in the foreground of the photo. A wave propagating in the upstream direction can be seen. Waves, and thus oscillating behavior in general, are undesired because they are likely to affect the discharges in the main canal and the lateral off-takes.

A number of other authors have investigated instabilities related to gate operation in irrigation canals in general or more specifically instabilities of AMIL gates.

Litrico et al. (2007) developed a general method for stability analysis of automatic gates in open channels. The Saint-Venant equations (one-dimensional shallow water equations) for the open-channel dynamics were combined with a model of the automatic gate in order to derive the governing equations. The method was based on linearization and Laplace transform of these governing equations. To simplify, only a static relationship between the gate opening and the water level was assumed, i.e., the gate is in equilibrium with the water level at each instant. This was based on the assumption that gate dynamics are negligible in front of the pools dynamics. Litrico and Fronton (2009) used a similar approach also throughout.

Stability of AMIL gates was specifically investigated in Corrigan et al. (1977, 1980) and Ramirez-Luna (1997). Corrigan et al. (1977) investigated an AMIL gate connected to a short, level pool and considered a dynamic interaction between the gate position and the water level. A calibration of the gate that results in zero total decrement was implicitly assumed. The model was linearized and the step responses of the linear and the nonlinear systems were compared. By means of the Laplace transform, a transfer function of the linear system was derived. Instabilities were discovered and their existence was related to the value of the damping parameter.

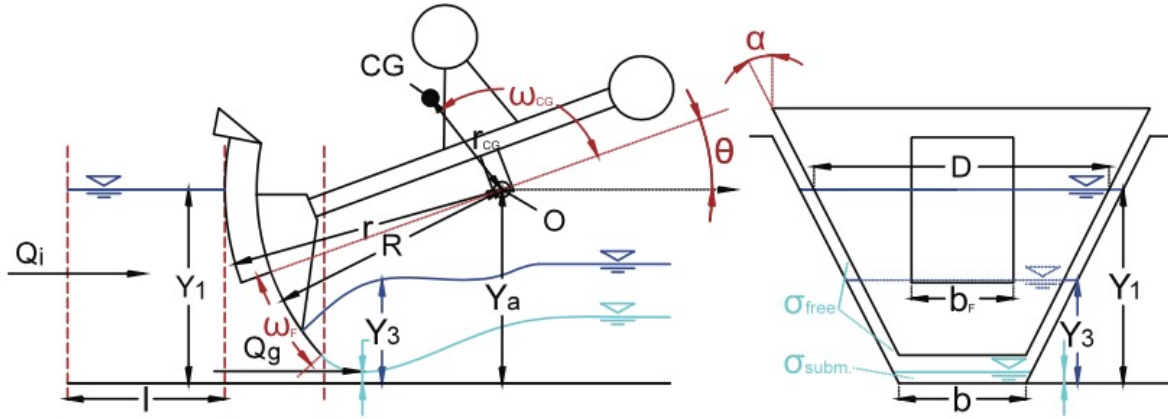

Fig. 2. (Color) Longitudinal and cross-section illustration of gate giving the geometric parameters

$$I \frac{d^2\theta}{dt^2} + c_\omega \frac{d\theta}{dt} = M_w(\theta, Y_1) + M_g(\theta)$$

$$M_g(\theta) = -mr_{CG}g \cos(\theta + \omega_{CG})$$

$$M_w(\theta, Y_1) = -b_F \int_R^r \hat{r} p(\hat{r}, \theta) d\hat{r} \quad (p(\hat{r}, \theta, Y_1) = \rho g \{Y_1 - [Y_a - \sin(\theta)\hat{r}]\})$$

$$= -b_F \rho g \left[\frac{r^2 - R^2}{2} (Y_1 - Y_a) + \frac{r^3 - R^3}{3} \sin(\theta) \right]$$

Gate rotational dynamics

Upstream water level change

$$\frac{dV}{dt} = Q_i - Q_g$$

$$V = b l Y_1 + \tan(\alpha) l Y_1^2$$



$$\frac{dY_1}{dt} = \frac{1}{l[b + 2 \tan(\alpha) Y_1]} (Q_i - Q_g)$$

$$\frac{d}{dt} \theta_1 = \theta_2$$

$$\frac{d}{dt} \theta_2 = C_1 \theta_2 + C_2 (\tilde{Y}_1 - \tilde{Y}_a) + C_3 \cos(\theta_1) + C_4 \sin(\theta_1)$$

$$\frac{d}{dt} \tilde{Y}_1 = \frac{C_6}{\tilde{b} + 2 \tan(\alpha) \tilde{Y}_1} \{ Q_n Q_i'(\tilde{t}) - Q_g[\theta_1, \tilde{Y}_1, \tilde{Y}_3(\tilde{t})] \}$$

which is a system of the form

$$\frac{d}{d\tilde{t}} \mathbf{x} = \mathbf{F}(\mathbf{x}, \tilde{t})$$

with states $\mathbf{x} = (\theta_1, \theta_2, \tilde{Y}_1)^T := (\theta, d\theta/d\tilde{t}, \tilde{Y}_1)^T$.

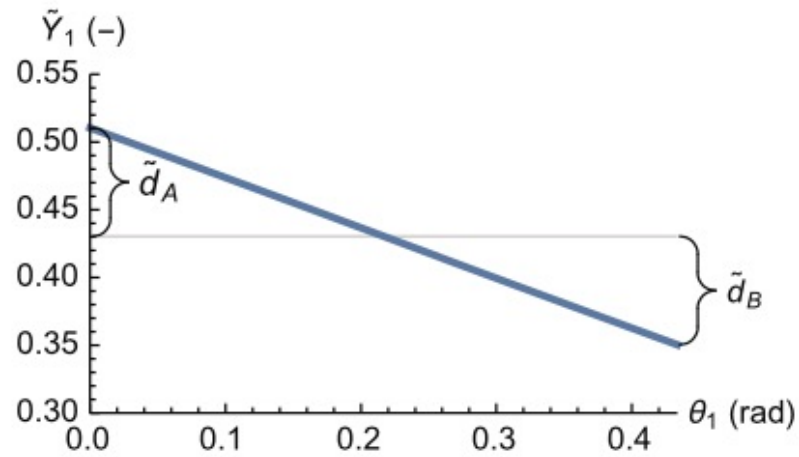
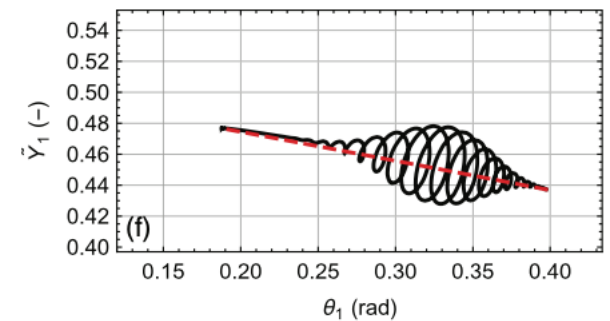
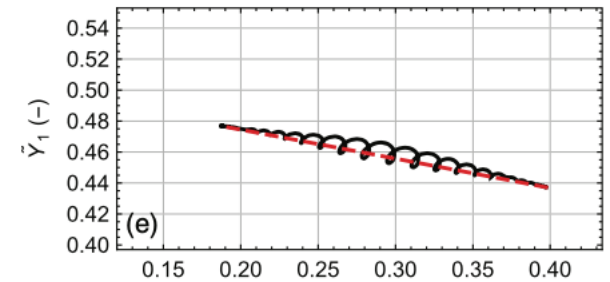
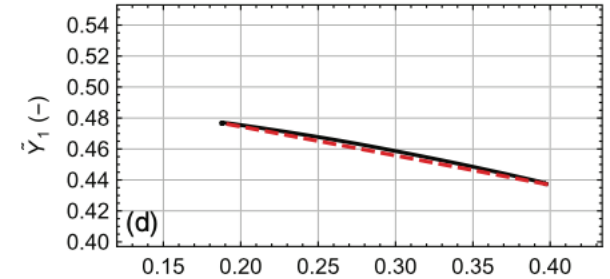
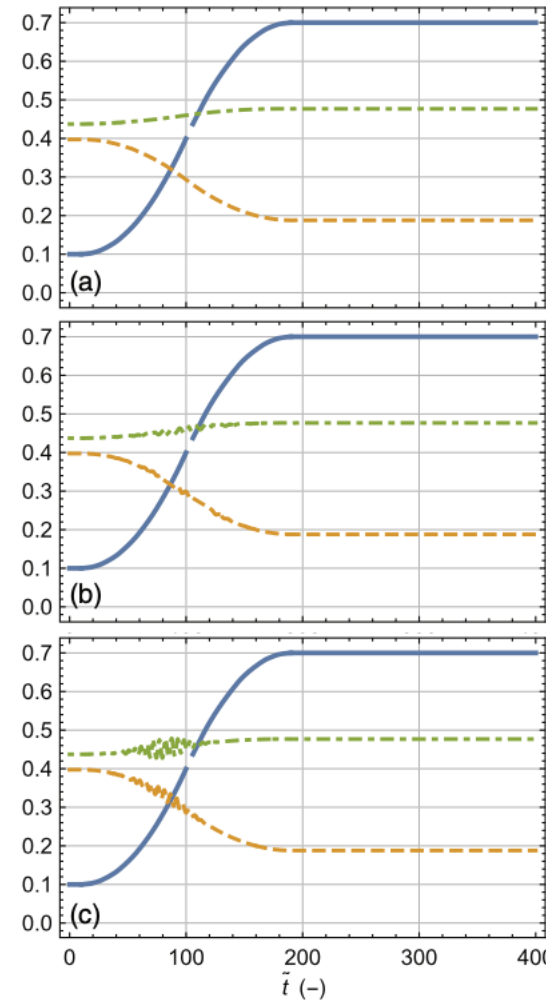

Fig. 4. (Color) Equilibrium position in the projected state space for varying Q'_i : the two components \tilde{d}_A and \tilde{d}_B (above and below gate axis) of the total decrement are shown



— $Q'_{in} (-)$ - - - θ_1 (rad) - - - $Y_1 (-)$
- - - Eq. position — Trajectory

Instability

Response to step function

Periodic behaviour (limit cycle)

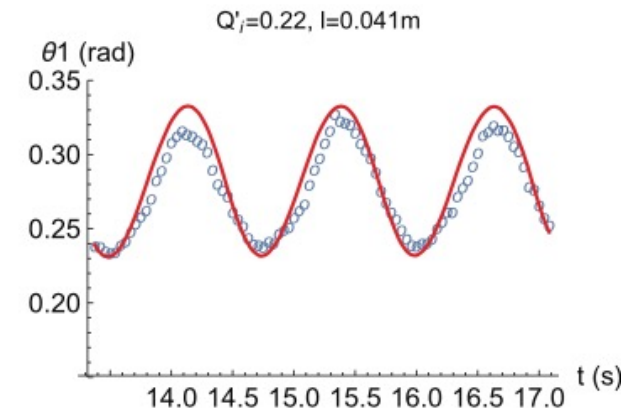
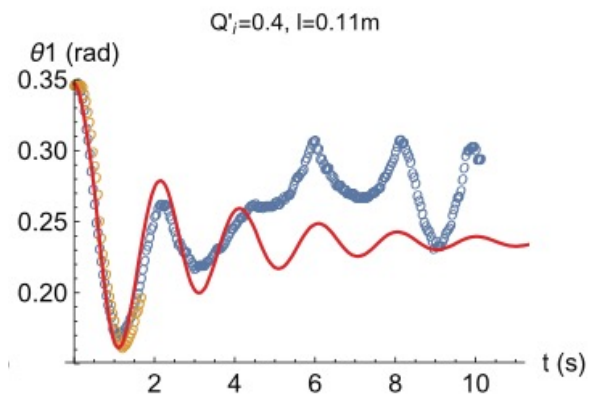

Advantages and disadvantages of upstream regulation

Advantages

- simplicity; possibility of regulation by means of simple, rustic and inexpensive structures (weirs)



Disadvantages

- Impossible to irrigate on demand
- difficulties in estimating the flow rate to be introduced into the network (flow rate required + en-route losses)
- difficulties in coping with unexpected non-consumption of water¹

¹ following, for example, closure of the valves during a storm → loss of water stored in the tabs

Constant level downstream valve (AVIO valve)

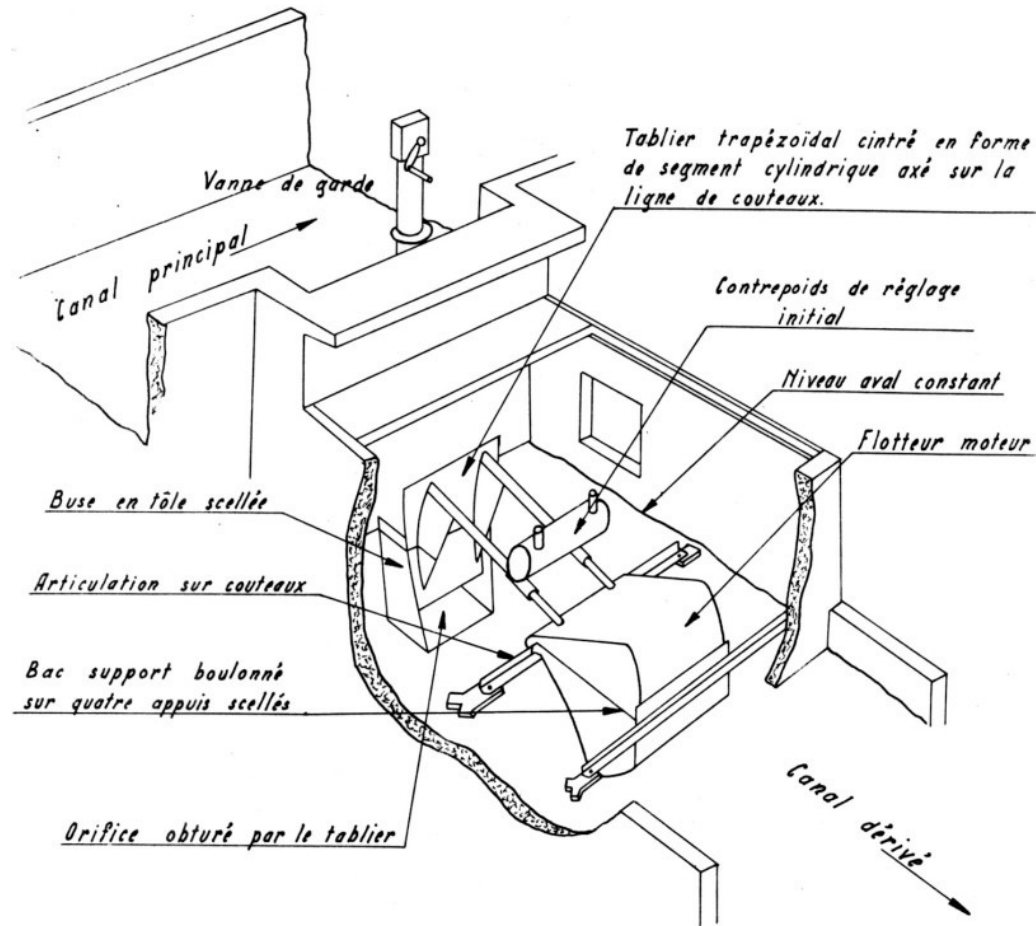

Downstream constant level valve



Figure 1

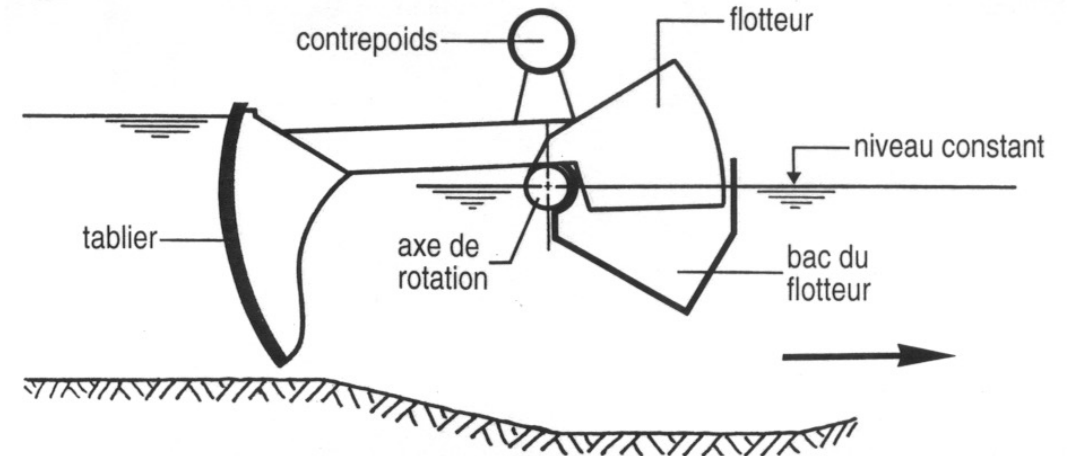
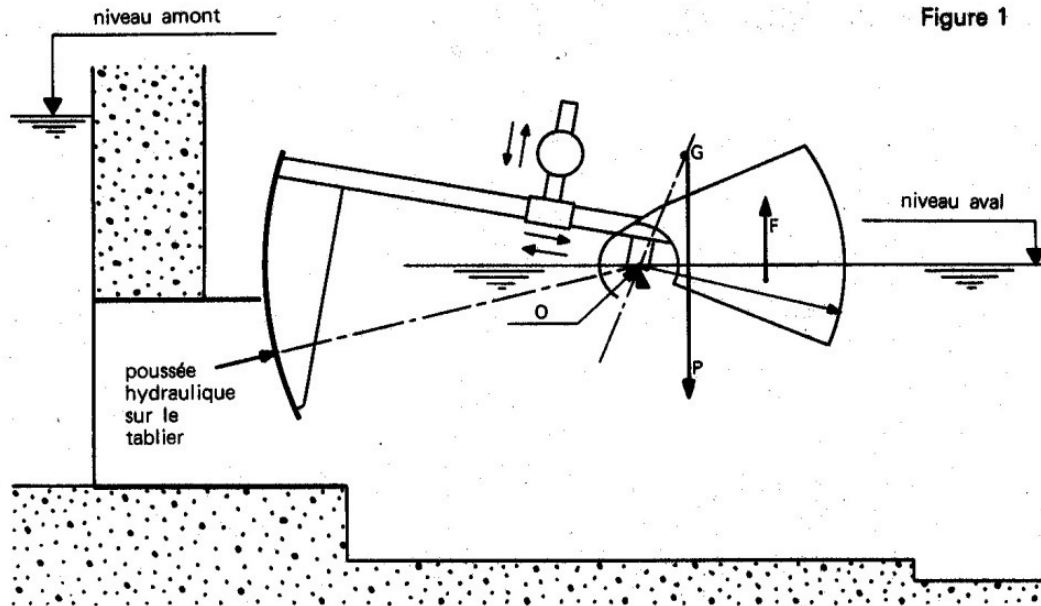

WORKING PRINCIPLE:

The torques involved are that due to the weight P and that due to the buoyancy F on the float. The movable counterweight allows the device to be adjusted to bring the centre of gravity to the desired position.

The valve is balanced so that these two torques are equal and opposite for any position of the gate leaf, when the downstream level is at the level of the hinge pin (adjustment level).

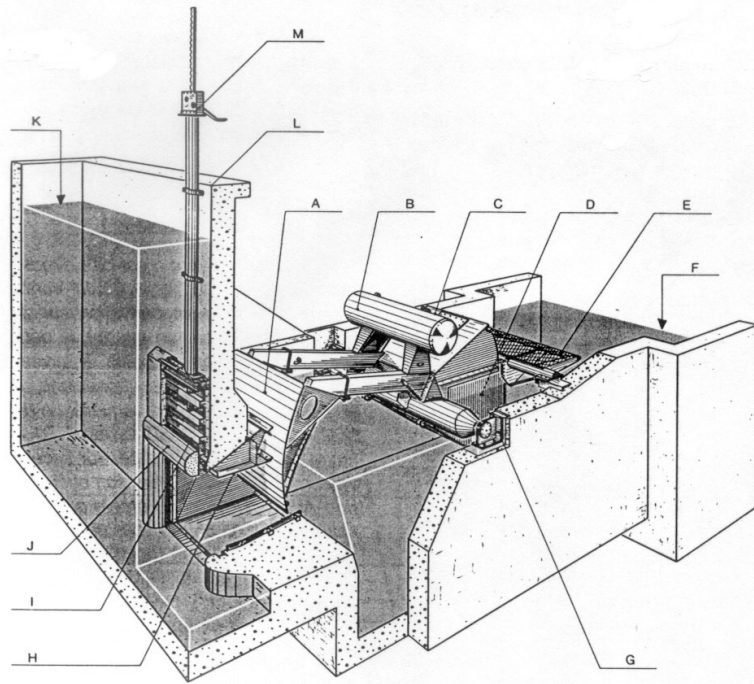

- A Tablier
- B Contrepoids
- C Flotteur
- D Bac du flotteur
- E Passerelle métallique
- F Niveau aval réglé
- G Palier
- H Buse en tôle scellée
- I Vanne de garde
- J Entonnement profilé
- K Niveau amont variable
- L Passerelle
- M Cric de manœuvre de la vanne de garde

Implantation type d'une vanne AVIO.

Valve with constant downstream level placed after an orifice (Avio valve)

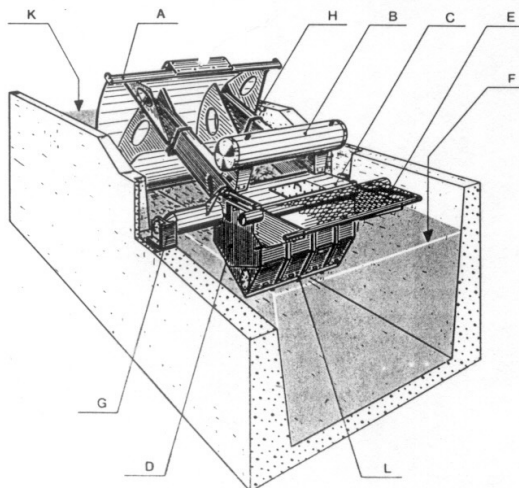

- A Tablier
- B Contrepoids
- C Flotteur
- D Bac du flotteur
- E Passerelle métallique
- F Niveau aval réglé
- G Palier
- H Pièce fixe scellée
- K Niveau amont variable
- L Fente de communication du bac

Implantation type d'une vanne AVIS.

Valve with constant downstream level placed across the entire section of the canal (Avis valve)

Valve with constant downstream level behind orifice (top) and on channel (bottom)

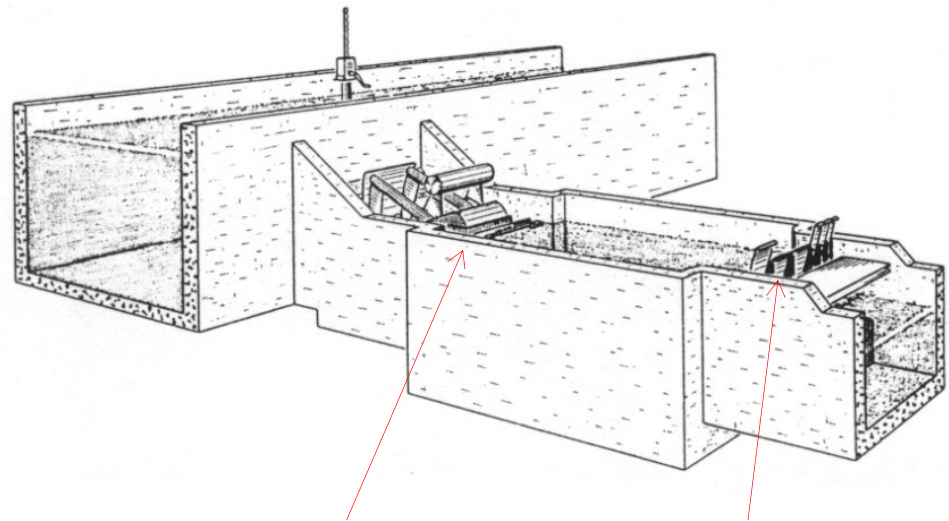

Valves with constant downstream level

Mask module batteries

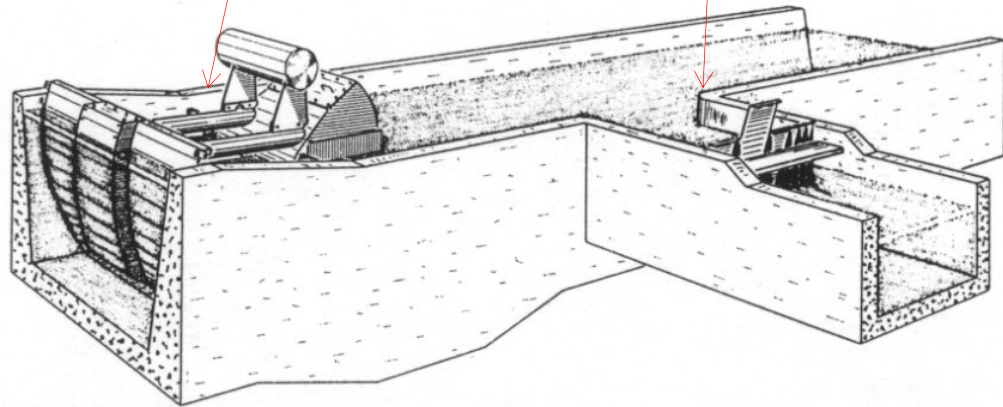

Disc valves

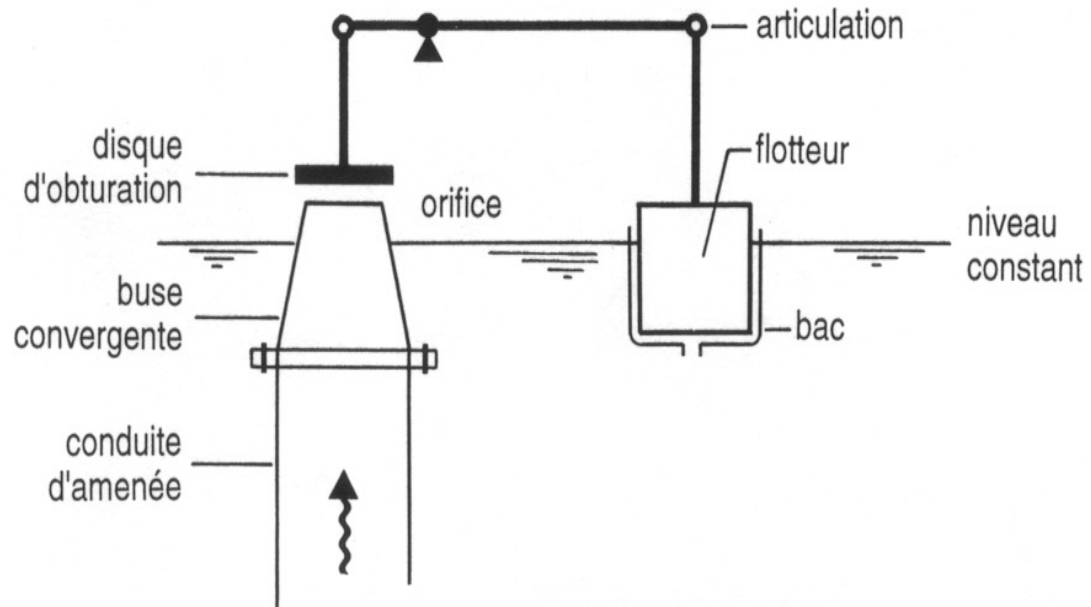

How a disc valve works

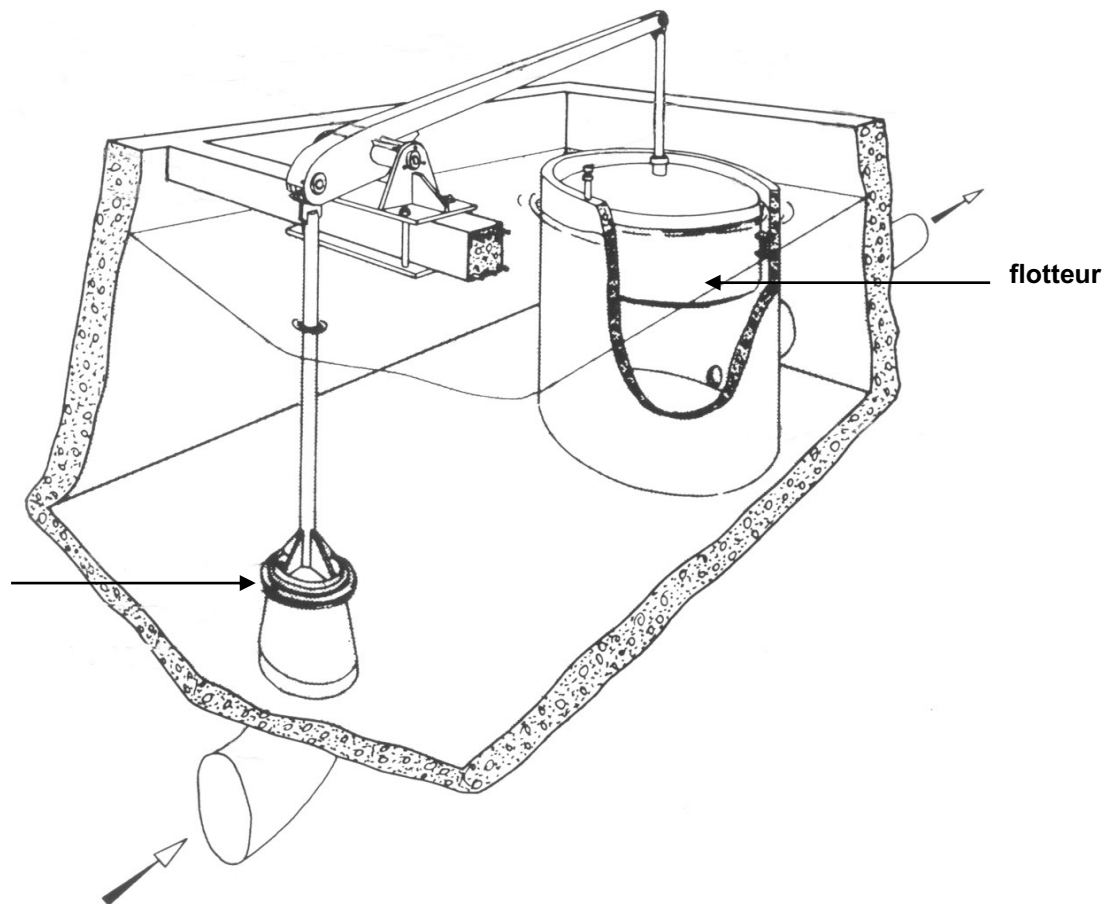

Schematic differences between the two regulations

Régulation par l'amont

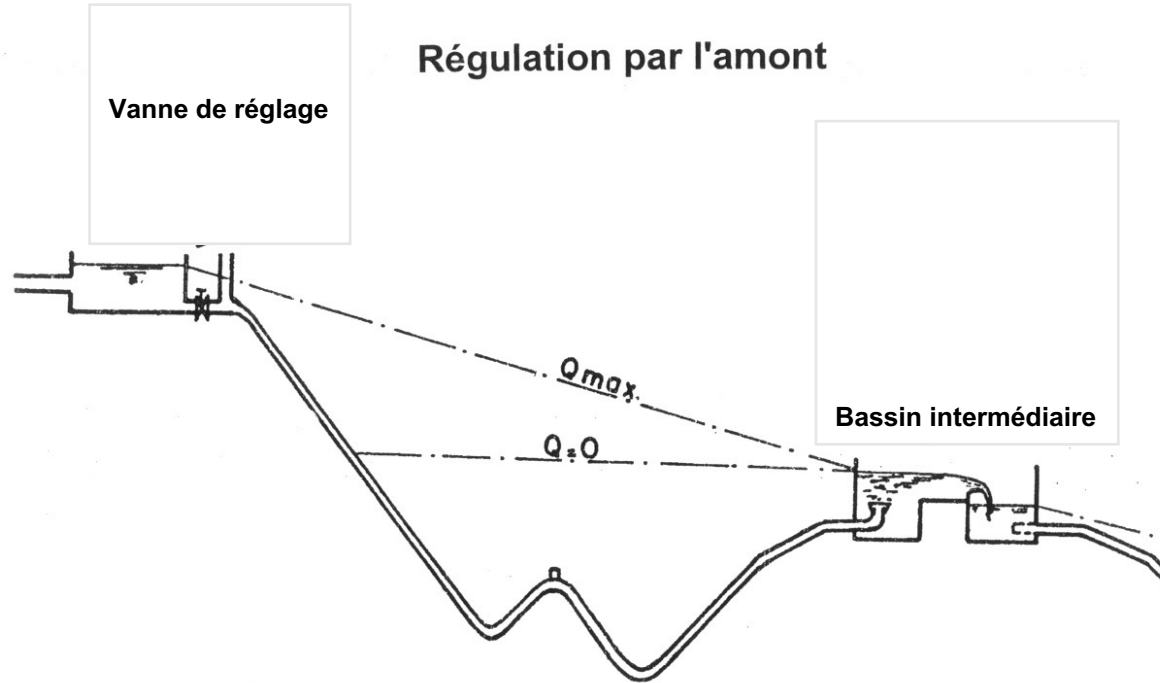

Régulation par l'aval

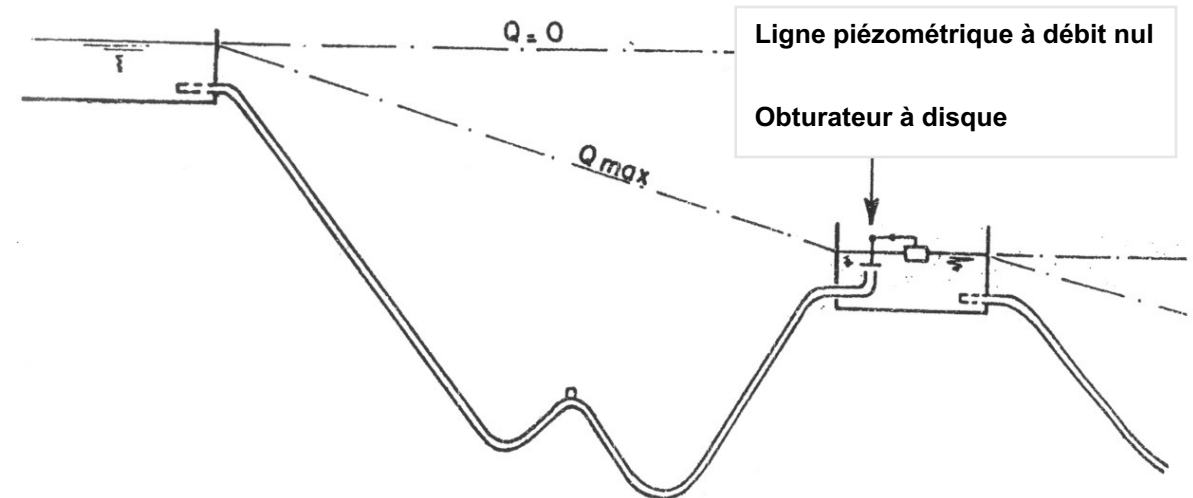

Plan and cross-section of a section of canal with downstream regulation

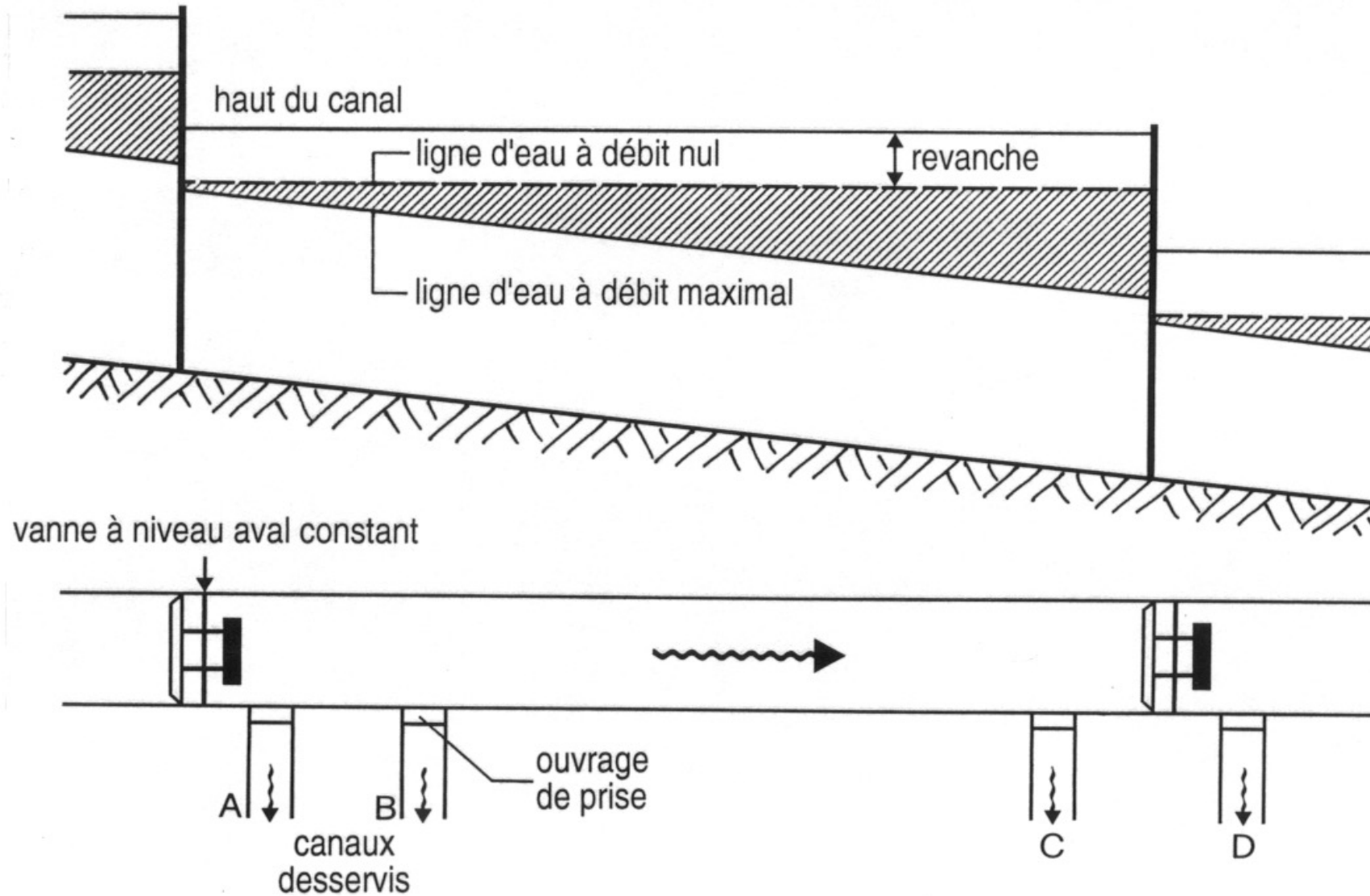

Advantages and disadvantages of downstream regulation

Advantages

- automatic flow regulation
- possibility of irrigating on demand

Disadvantages

- position of the water line at zero flow: succession of horizontal planes
 - ➔ need to raise the banks (prohibitively expensive when the slope > 0.0003)
- high valve density
- difficulty in obtaining a stable regime in the canals



Use of valves with constant downstream level

- **in series** to allow regulation downstream of the network
- **locally**, upstream of a diversion or at the start of a diverted canal to regulate water levels from time to time
- **at the outlet of a reservoir** to regulate the flows injected into the network



châssis à 3 articulations

Operating principle of a cylindrical valve

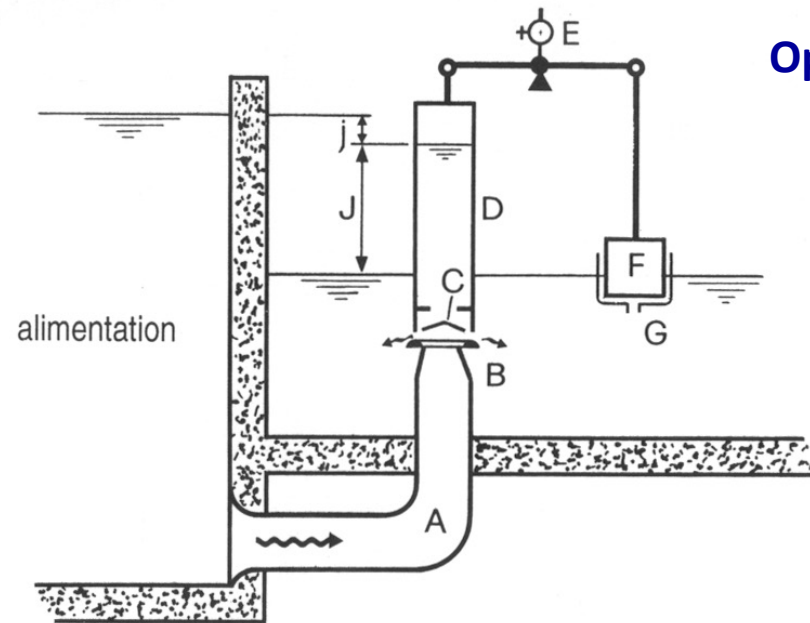

- A : coude convergent
- B : seuil
- C : déflecteur
- D : chemise cylindrique
- E : contrepoids de réglage
- F : flotteur
- G : bac du flotteur
- J : p. de charge dans la vanne
- j : p. de charge dans la conduite

Canal intake structure with regulation by cylindrical valve

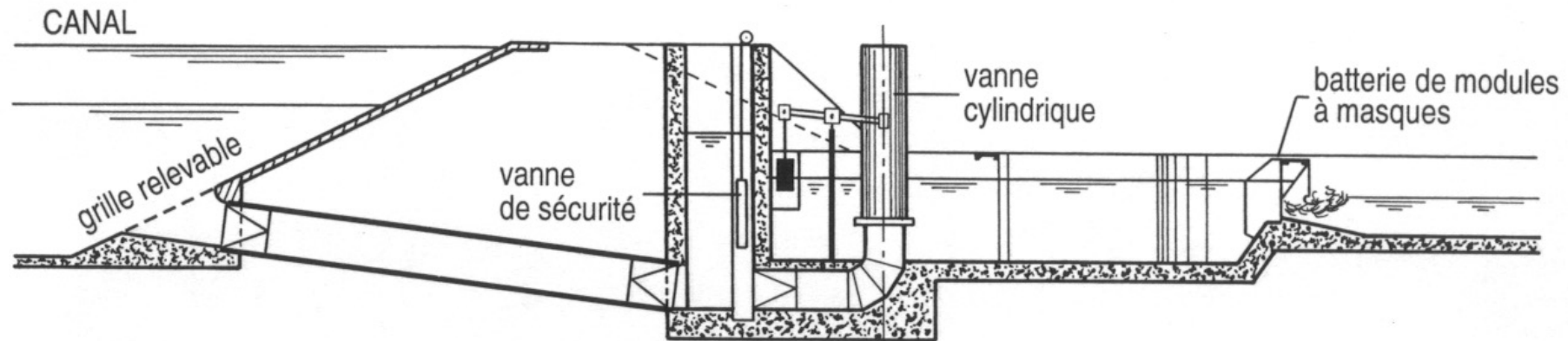

Water (re)distribution structures

Hydraulic structures installed at the head of canals and whose function is to divert part of the flow of the adductor canal according to :

- a given flow rate
- a given ratio (proportional distribution)



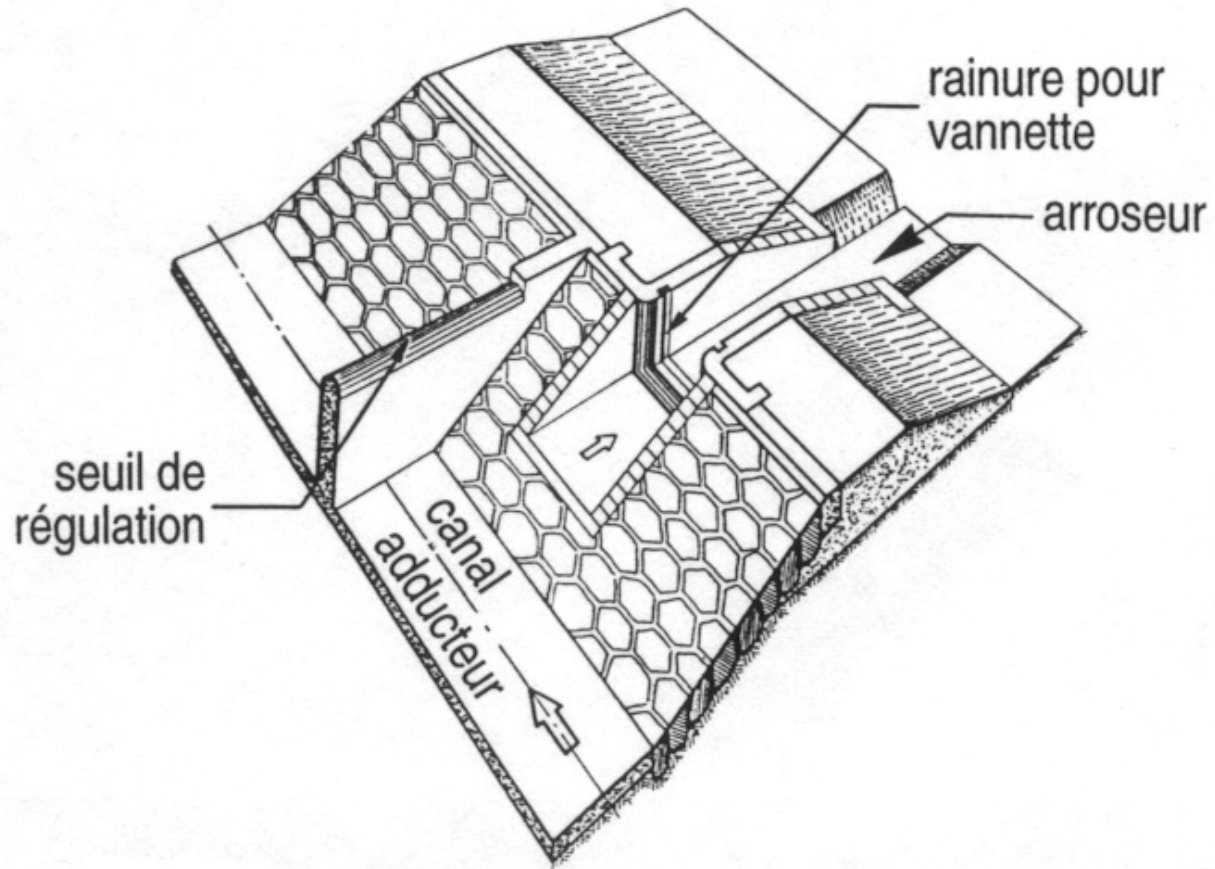

Surface weir intake

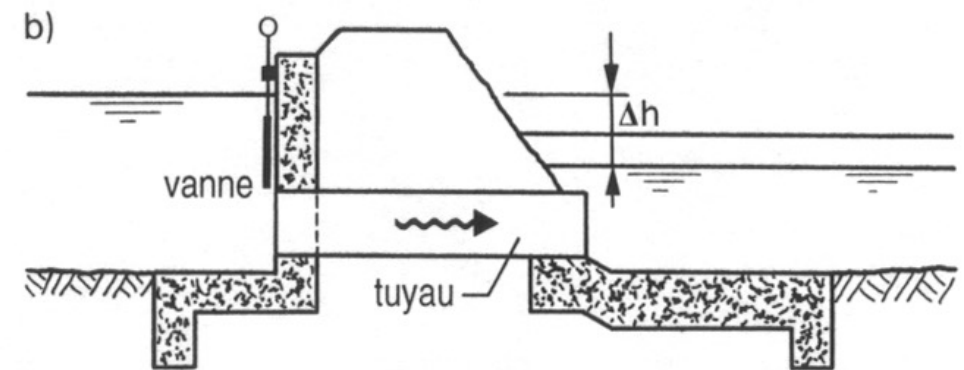
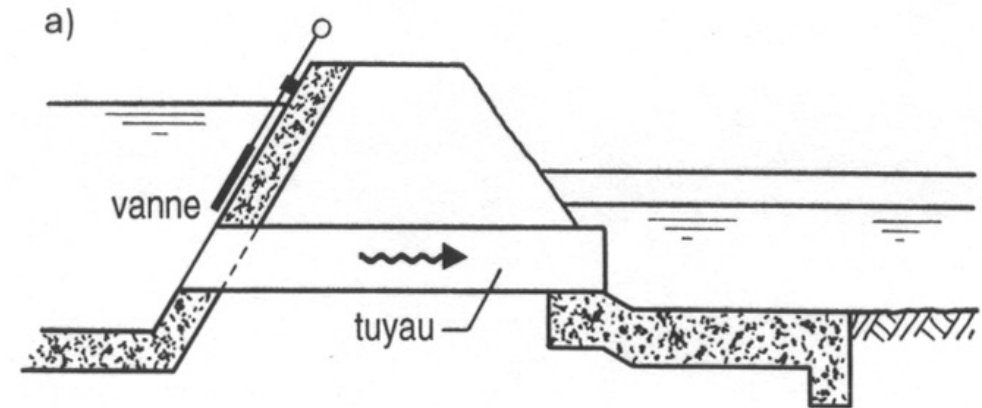

Orifice type intake

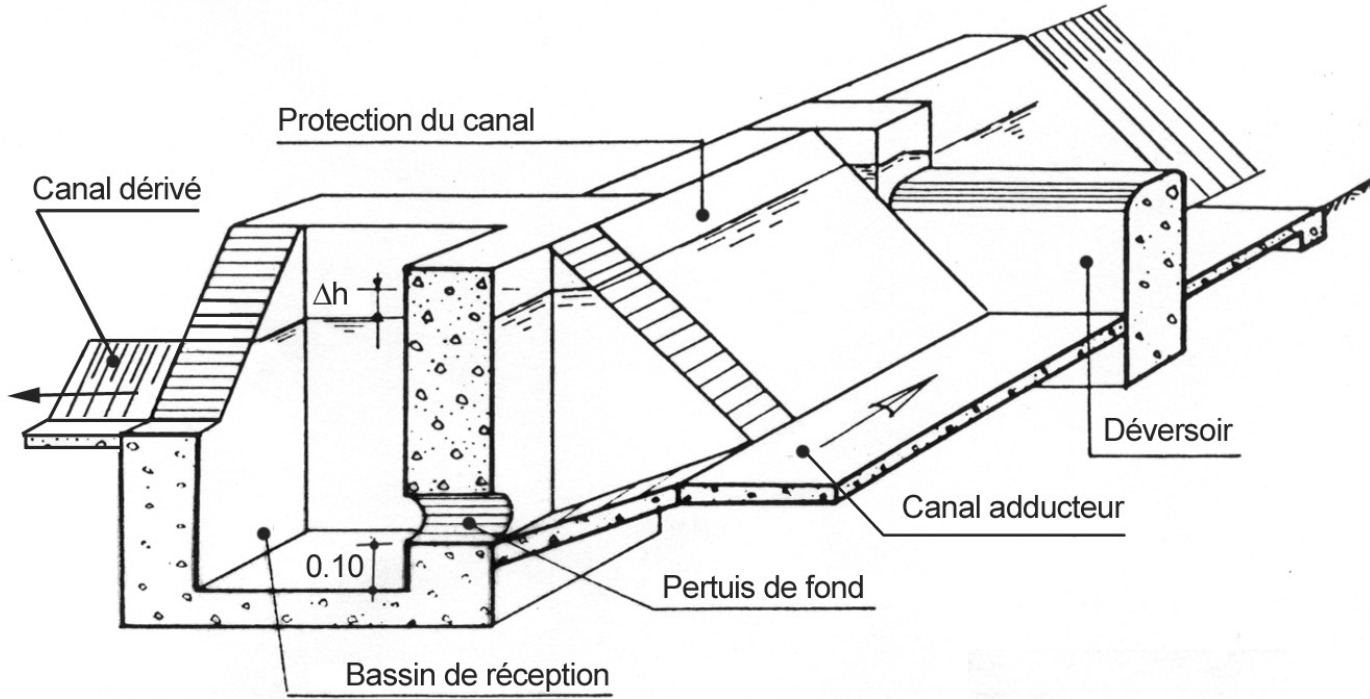

Bottom orifice

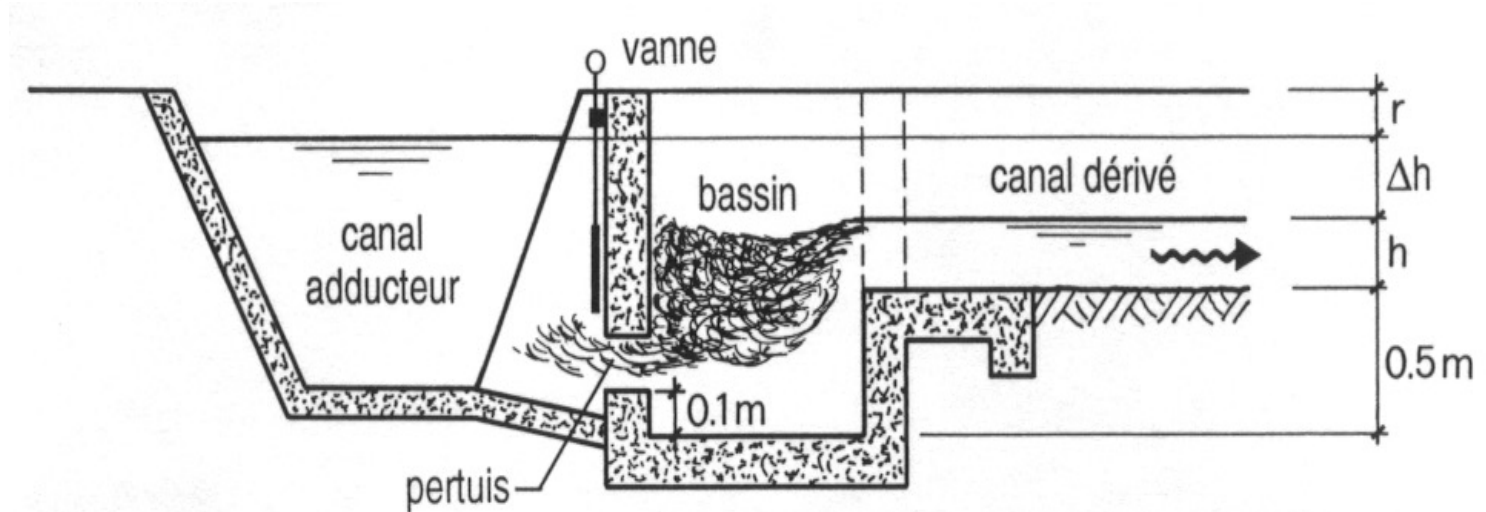

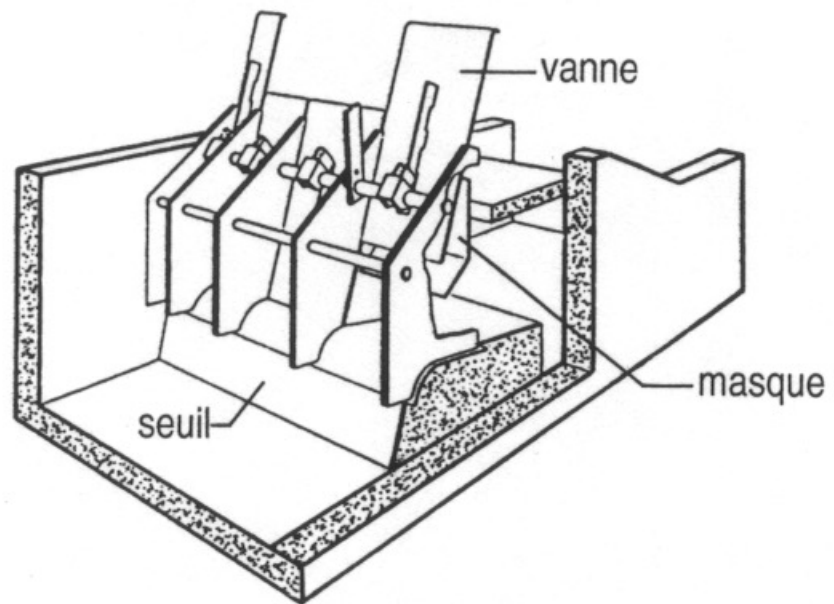

Mask module

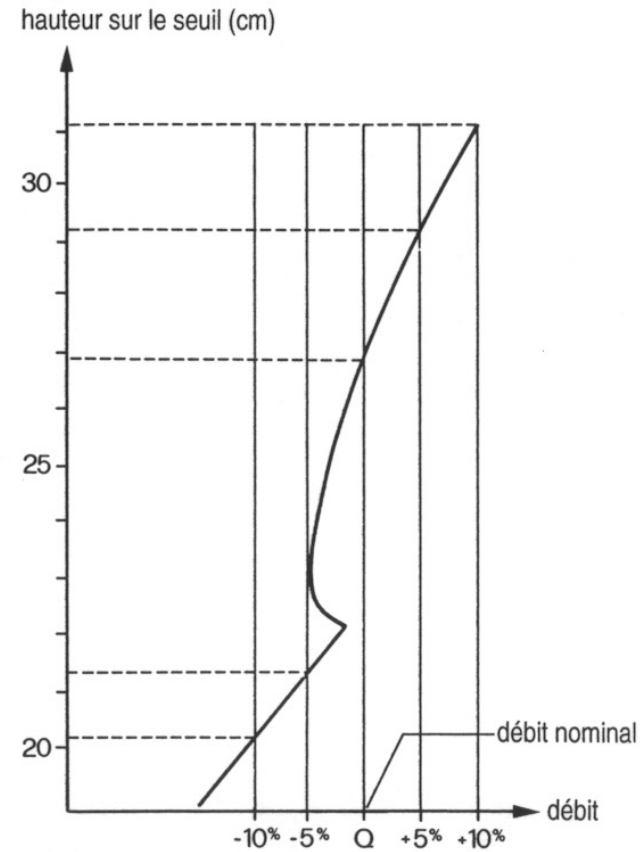

Campus



Field



Campus



Field

Notice the possibility to combine several gate apertures by which means the total flow is simply the sum thanks to the constant water level upstream (e.g., maintained by a control structure)

Schematic diagram and operating curve for a 1-mask module

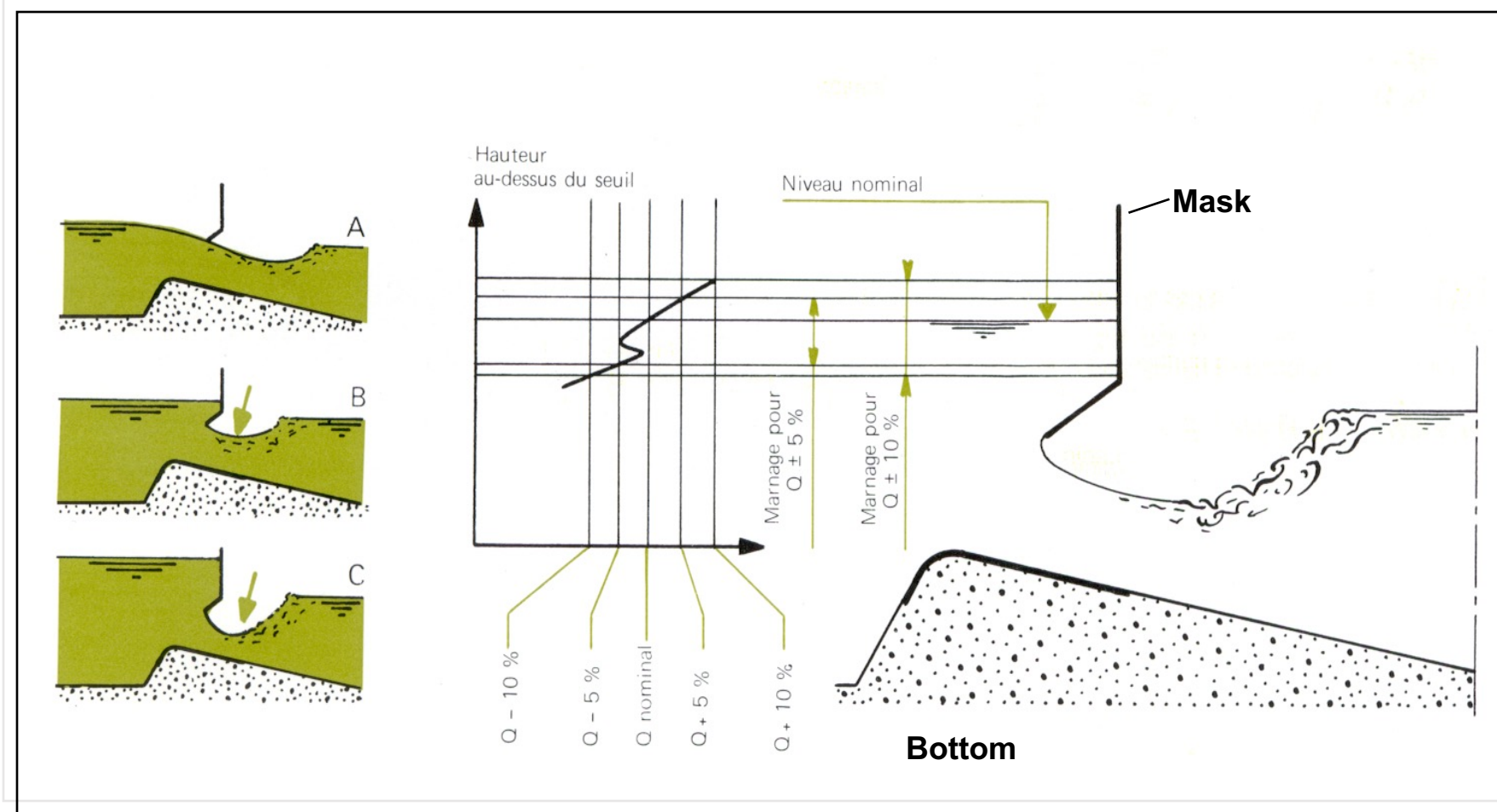

The particular shape of the bed and mask means that when the load increases, the contraction is accentuated, which reduces C and therefore the flow rate.

Schematic diagram and operating curve for a 2-mask module

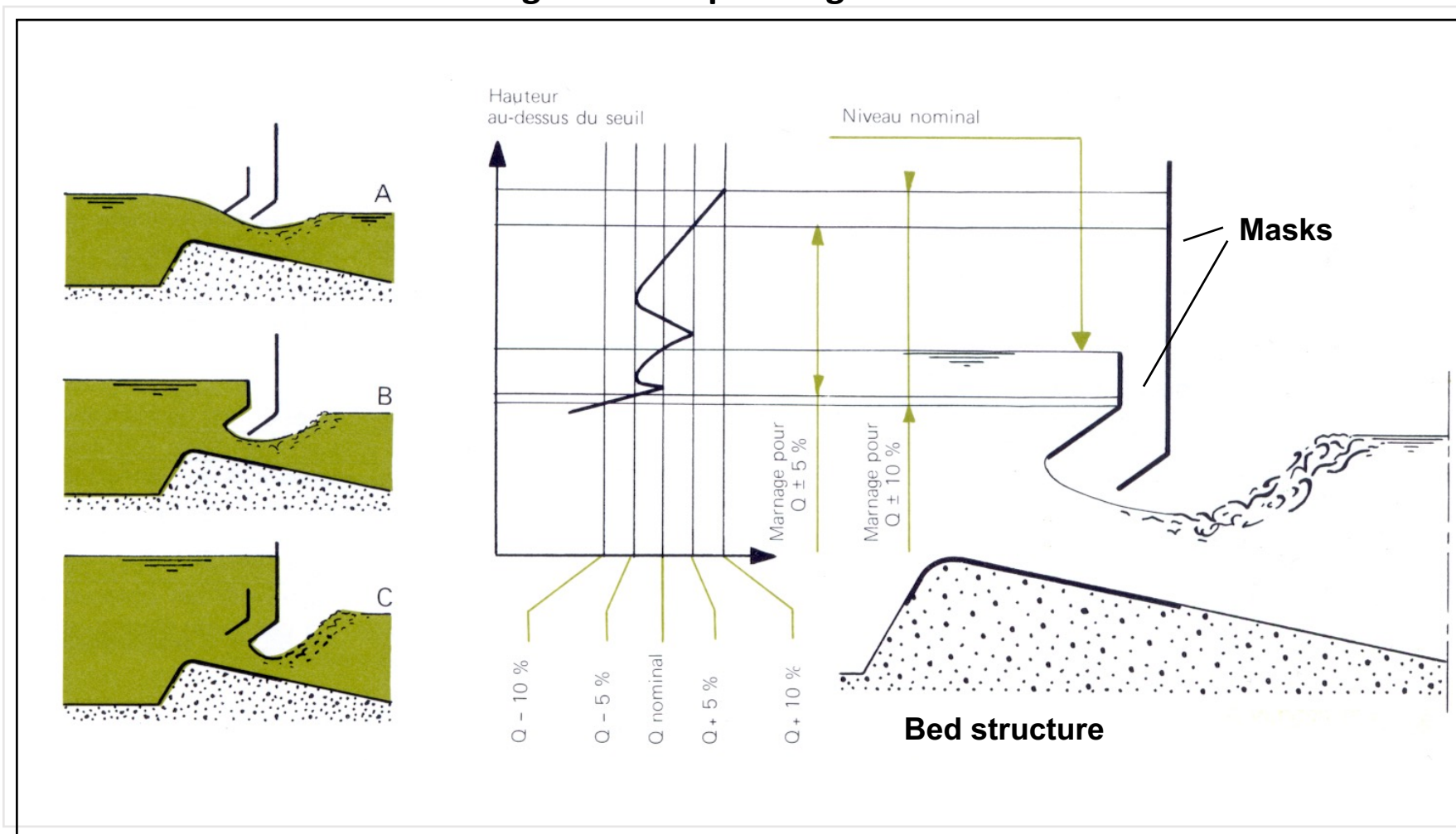

Thanks to the contraction produced by the first mask, the second mask can be brought closer to the threshold, forming an orifice with a reduced cross-section.

Examples of equipped intakes

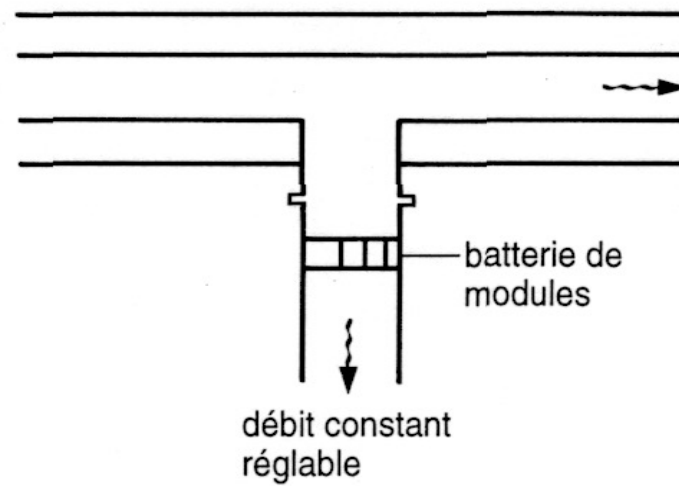
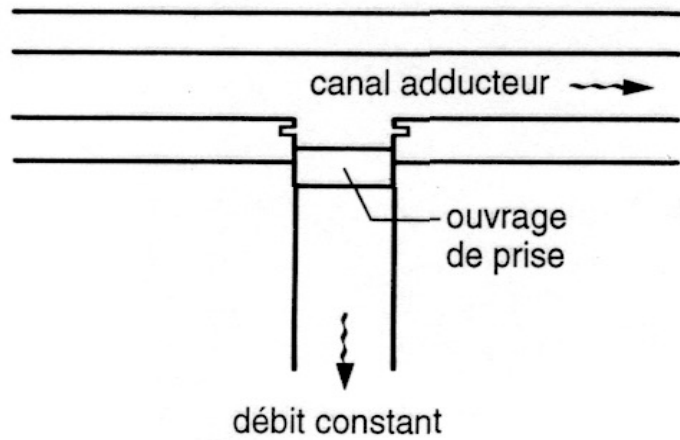

Water level +/- cst in the inlet channel

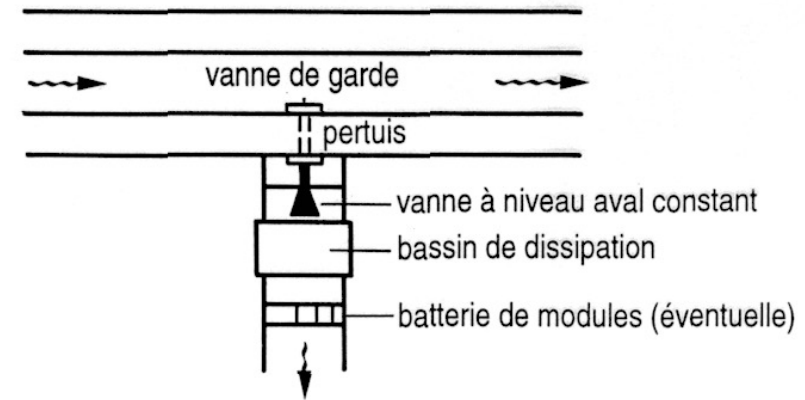
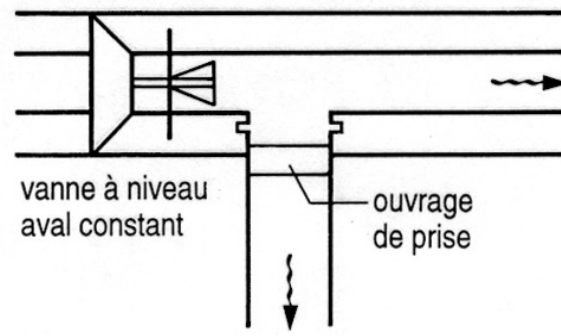
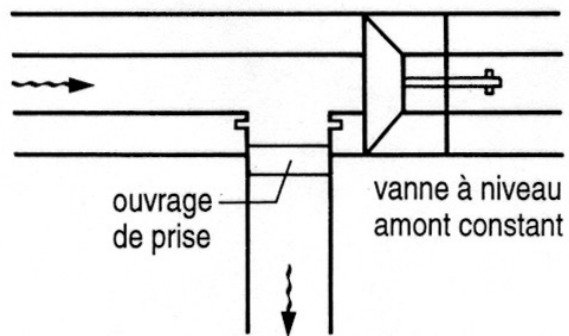

Variable water level in the inlet channel

FIGURE 10

Batterie de modules associée à une vanne à niveau aval constant installée en tête d'un canal dérivé.

(prise sur canal ou retenue à marnage excédant les tolérances des modules)

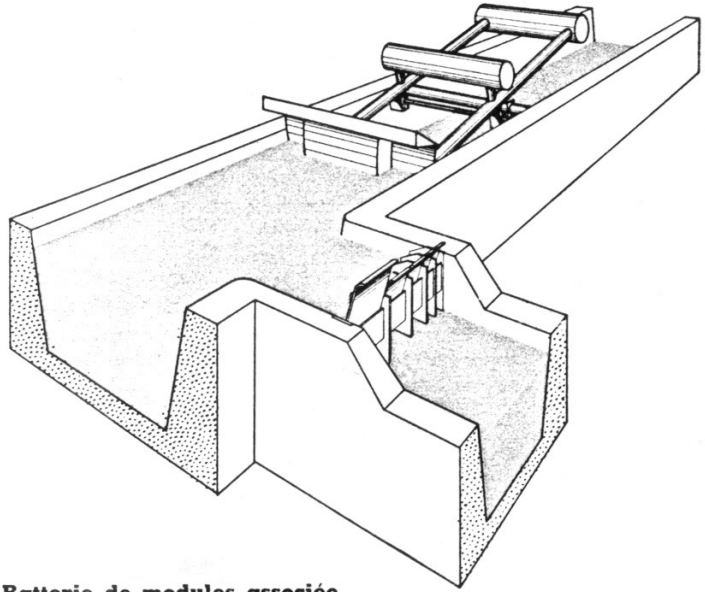
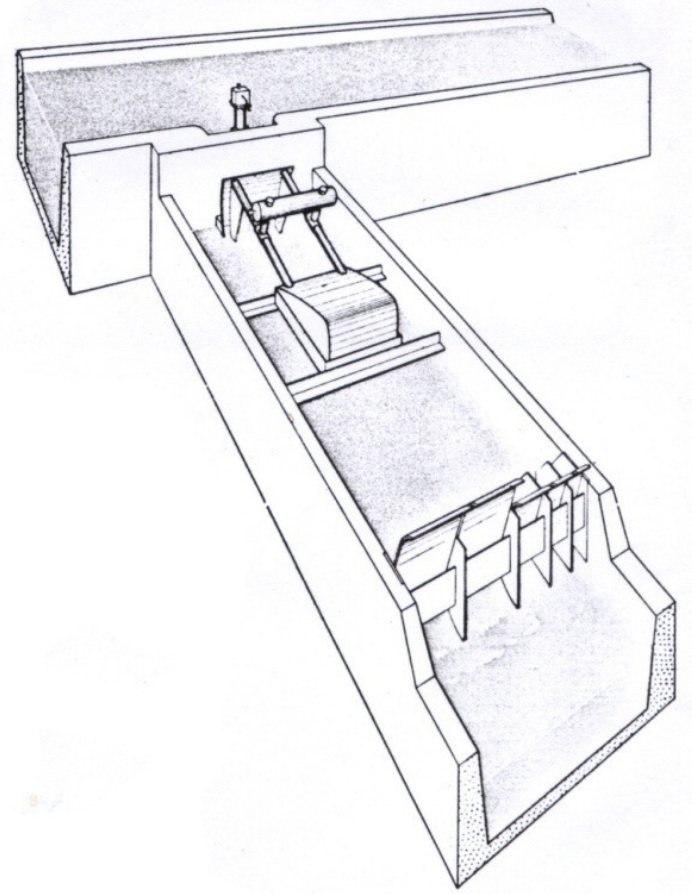

Batterie de modules associée à une vanne à niveau amont constant installée sur le canal principal.

(prise sur canal en commande par l'amont)

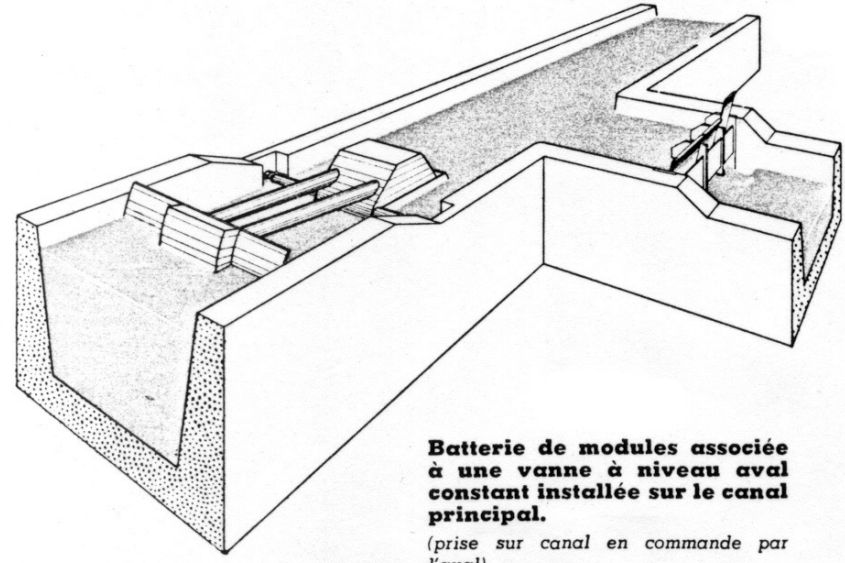

Batterie de modules associée à une vanne à niveau aval constant installée sur le canal principal.

(prise sur canal en commande par l'aval)

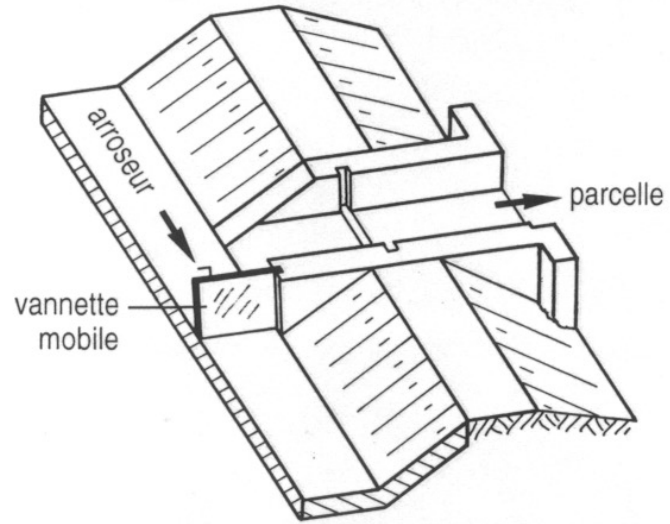

All-or-nothing distribution

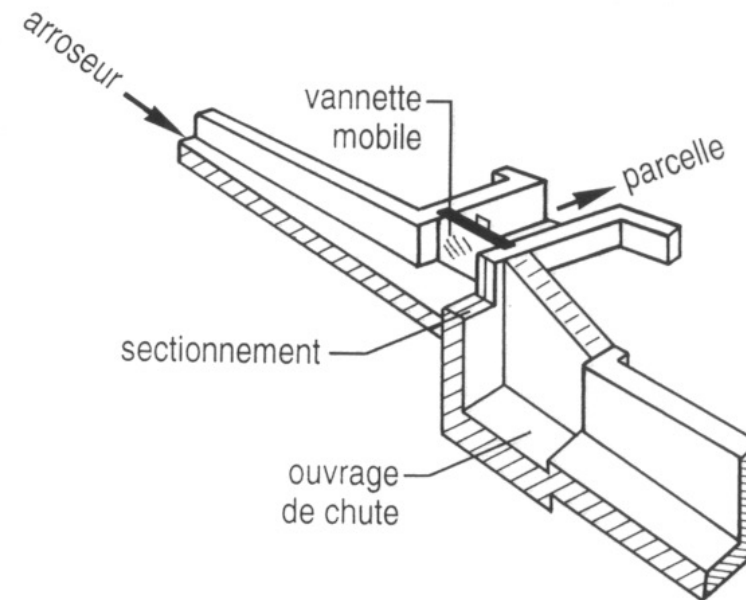

**Local distribution systems
(usually at the plot)**

"All-or-nothing" distribution with drop

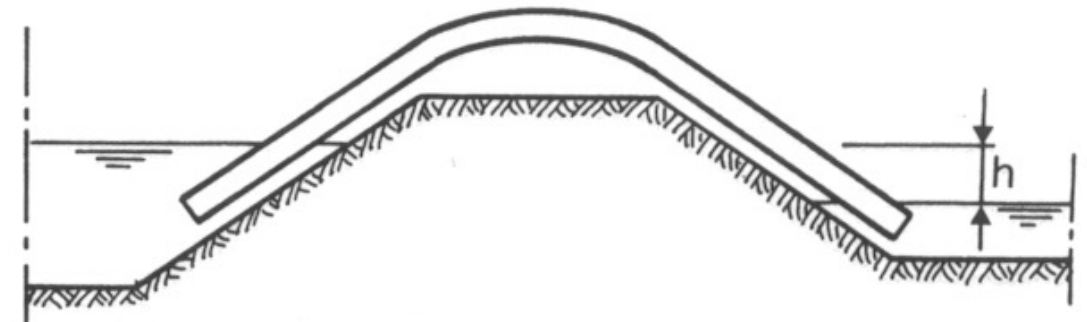

Distribution via syphon